



C.Nord

WIRELESS GLASS BREAK DETECTOR

«CN-Glass»

Installation Guide



Introduction

The detector «CN-Glass» (hereinafter, the Detector):

- is intended for detecting destruction of all known kinds of construction glass: common, quenched, patterned, armored, multilayer and laminated with polymer film, glass units, as well as hollow glass blocks installed in structural units (openings) and/or interior elements of closed spaces;
- transmits status messages via two-way communication in the 433.05 to 434.79 MHz frequency range to the control panel (hereinafter, CP) supporting the «CN-Contact-R» wireless communication protocol;
- provides case and wall tamper protection;
- may be installed on the wall, ceiling or on a pier between the monitored glass and curtains;
- ensures remote monitoring of controlled glazed structures of any shape;
- provides multilevel microprocessor signal processing and functional self-test;
- adjusts the sensitivity depending on the interference situation at the monitored facility;
- operates at one of 4 possible operating frequencies;
- automatically switches over backup frequency in case of impairment of interference conditions at the main operating frequency;
- is able to switch on and off an identification and status LED indication by the CP relevant command.

Field of Application

The Detector can be applied in offices, shops, museums, exhibition halls, banks, accommodation rooms, etc.

Specifications

Table 1

Parameter	Value
Maximum detection range	6 m
Angle of coverage	120°
Installation height	at least 2 m (see Figures 3 – 7)
Operating temperatures range	from minus 20 to +45 °C
Relative air humidity at 25 °C	up to 90 %
Broadcast period (programmed during the CB binding)	10 sec to 10 min
Weight (without power batteries)	maximum 0.1 kg
Dimensions	maximum 105 x 50 x 40 mm
Battery life (under normal conditions, and messages transmitting period not less than 30 sec)	up to 3 years
IP rating	IP30

Binding with the CP

The binding procedure is intended for the logging of the Detector in the CP (repeater), assignment it's number, address and the operating frequency chosen for this CP, initialization of the data coding system and exchange of service information.

1 Install the CR2032 backup power supply battery into the holder located on the reverse side of the Detector PCB.

2 Install the PCB into the Detector case, thereafter install the CR123A main power supply battery.

3 LED indicator blinking green displays the Detector readiness to the binding procedure.

In case of the LED indication absence, the Detector should be transferred to the «Binding» mode by closing the «RESET» contacts until the green LED indicator starts blinking.

4 In case of successful binding with the CP (repeater), the LED indicator blinks red for 1 sec.

5 The binding procedure is limited up to 100 sec, whereupon the Detector transfers to the sleep mode. To restart the «Binding» mode close «RESET» contacts for a short time.

Note – The zone number is determined in accordance to the CP user manual.

LED Indication

Table 2

Detector Status	Indication
«Binding» mode	LED indicator blinking green periodically
«Alarm»	LED indicator single time blinking red
«Tamper»	see section «Communication Quality Appraisal»
«Identification»	LED indicators alternate blinking red and green
«Adjustment»	LED indicator blinking green every 1 sec under the DIP-switch «3» is ON
«Interference»	the LED indicator lights up green

Choosing the Detector Location

Before installing the Detector, get acquainted with the following requirements:

- it is recommended to install the Detector at least 2 m height (see examples of installation in Figures 3 – 7);
- when choosing the place of installation, the Detector detection zone location must be taken into account (Figure 1);
- distance (L) between the Detector and the farthest point of the monitored glass should not exceed 6 m;
- during joint operation with an active ultrasonic Detector, distance between Detectors must be not less than 1 m;
- the entire surface of the monitored glass should be available within the direct visibility of the Detector.

The Detector must be located within the radio visibility zone of it's repeater; therefore, it is recommended to estimate the quality of communication with the CP (repeater).

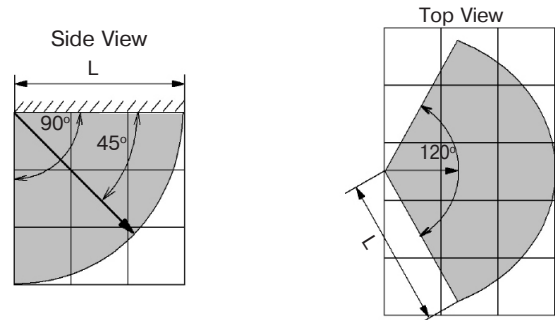

Figure 1 – Detection Pattern

Communication Quality Appraising

To estimate the communication quality:

- 1 Place the Detector on it's installation place;
- 2 Press the Detector tightly to a hard surface in order to close the tamper output;
- 3 Remove the Detector cover. Whereupon the Detector transmits a tamper message (the LED indicator lights red) and then the LED indicator displays communication quality with the CP by a three-grade scale (see Table 3).

Table 3

LED Indication		Communication Quality Appraisal	Recommendations
Color	Mode		
Green	Three blinks	Excellent	Install the Detector at this place
Green	Two blinks	Good	
Green	One blink	Communication established	Choose another place for installation or use a repeater*)
Red	Four blinks	No communication	

*) – «CN-Repeater»

Installation of the Detector

Remove the cover and PCB of the Detector and fasten the Detector with the help of screws. Choose the place of the Detector installation and mark out its fastenings using the Detector base (Figure 2) for the purpose. Fix the base by the screws (supplied).

To ensure the tamper control, the first screw should be screwed into the opening (1) at the base center, the second one must be screwed in a hole under the wall tamper (2).

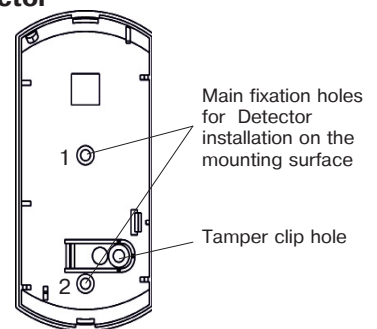

Figure 2 – The Detector Base

Adjustment

Set the «1», «2» and «3» DIP-switches to the OFF position. Install the power supply batteries. Estimate the interference situation in the room (the green LED indicator should not light up).

The green indicator lighting up means the high level of interference in the room. Remove the interference sources if possible.

Execute adjustment of the Detector as follows:

- set the «1», «2» DIP-switches to the ON position. After it shift DIP-switch «3» to the ON position – the «Adjustment» mode is displayed by the green LED indicator blinking once per second;
- close the cover;
- suspend a steel ball 21 – 22 mm in diameter on a 35 cm long thread near the farthest part of the monitored glass (ordinary, ornamental, armed, laminated), deflect it at an angle of 30 – 70° (see Table 4, 45° for hollow glass blocks). When the green LED indicator switches on, deliver a test blow.

Table 4

Glass thickness, mm	<3	3...4	4...5	5...6	6...7	>7
Ball deflection angle for ordinary, armed and ornamental glass, °	30	35	40	45	50	55
Ball deflection angle for hardened and laminated glass, °	45	50	55	60	65	70

In case the CP does not receive an alarm message after test blows, the Detector sensitivity must be increased by DIP-switches «1» and «2» (see Table 5).

Table 5

DIP-switch Position			Detector Operating Mode	
1	2	3		
ON	OFF		Sensitivity (detection range) adjustment	Decrease by 6 dB
OFF	ON			Decrease by 12 dB
ON	ON			Decrease by 18 dB (min)
OFF	OFF			Max. sensitivity
		OFF	Standby mode	
		ON		Acoustic channel setting

- this method produces the most reliable results; however, for adjustment the Detector for monitoring a multilayer glass or a small area of glass, it is allowed to use an AFT-100 type electronic glass break simulator manufactured by the «DSC» company in the «Plat/Singl» mode or an APC type glass break simulator manufactured by the «Argus Security» company. Besides, a simulator should be used for adjustment the Detector to multi-glazed windows;

- check the correctness of the Detector adjustment with the Detector cover installed;
- after completing the Detector adjustment, set DIP-switch «3» to the OFF position.

Features and Recommendations

1 The Detector backup power supply is energized whereas the main battery is installed.

2 The LED indication is switched off automatically in 10 minutes after the cover is closed. To restore the LED indication lighting it is enough to open the cover.

Detector Installation Examples

Correct Detector installation options see Figures 3 – 7, the incorrect one – Figure 8

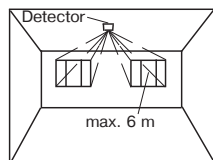

Figure 3 – Installing the Detector on the Ceiling

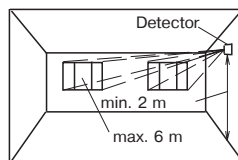

Figure 4 – Installing the Detector on a Side Wall

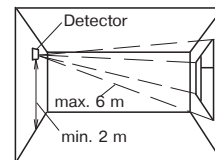

Figure 5 – Installing the Detector on the Opposite Wall

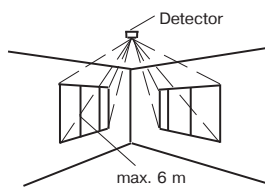

Figure 6 – Installing the Detector on the Ceiling (for window openings in the neighboring walls monitoring)

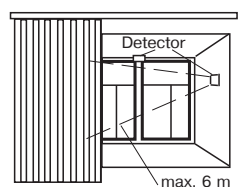

Figure 7 – Detector Installation between the Glass and the Curtains (Blinds) or on a Window Frame

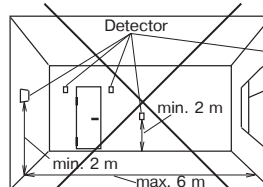

Figure 8 – Unauthorized Detector Installation Places

3 After the Detector energizing, self-testing process is activated. The process is accompanied by the LED indicator blinking once per second.

The LED indicator blinking red for 30 sec means a possible fault. In case of the situation repeat after the Detector is restarted, it is recommended to substitute the Detector.

4 The «DISARM» command ensures sound processing blocking in order to avoid false alarm in the rooms during labor hours and to save the battery charge. The «ARM» command transfers the Detector to a standby mode.

5 The «Identification» command allows to find the Detector assigned to the respective monitored zone.

Scope of Delivery

Each Detector unit package contains the items listed in Table 6.

Table 6

Description	QNT
Wireless glass break detector «CN-Glass»	1 pc.
Screw 3-3x30.016	2 pcs.
CR123A lithium power supply battery	1 pc.
CR2032 lithium power supply battery	1 pc.
Wireless glass break detector «CN-Glass». Installation Guide	1 copy

Storage and Transportation

1 The detectors in original package may be transported by any means of transportation in closed vehicles over any distances in compliance with the existing shipping rules concerning the respective means of transportation.

2 Storage conditions of the detectors: storage premises should not contain any current-conducting dust, acid and alkali fumes, as well as corrosive gases or those destroying insulation.

Manufacturer's Guarantees

«RIELTA» JSC guarantees conformity of the Detector to it's Technical Specifications if conditions of transportation, storage, assembling and operation are observed. The guaranteed storage period is 63 months since the date of manufacturing the Detector.

The guaranteed period of operation is 60 months since the date of commissioning within the storage period guaranteed.

For guaranteed maintenance, please contact:

«C.Nord» STCF
Russia, 190020, St. Petersburg,
Obvodny Channel emb., 199-201, build.13, BC «Obvodny Dvor»
Phone: (812) 327-16-36
E-mail: cnord@cnord.ru, support@cnord.ru, www.cnord.ru

Note – Warranty obligations do not apply to the power supply batteries.

Packing Certificate

The Detector «CN-Glass» has been manufactured in compliance with the active technical documentation, classified as fit for operation and packed by «RIELTA» JSC.

Packing date _____ month, year