

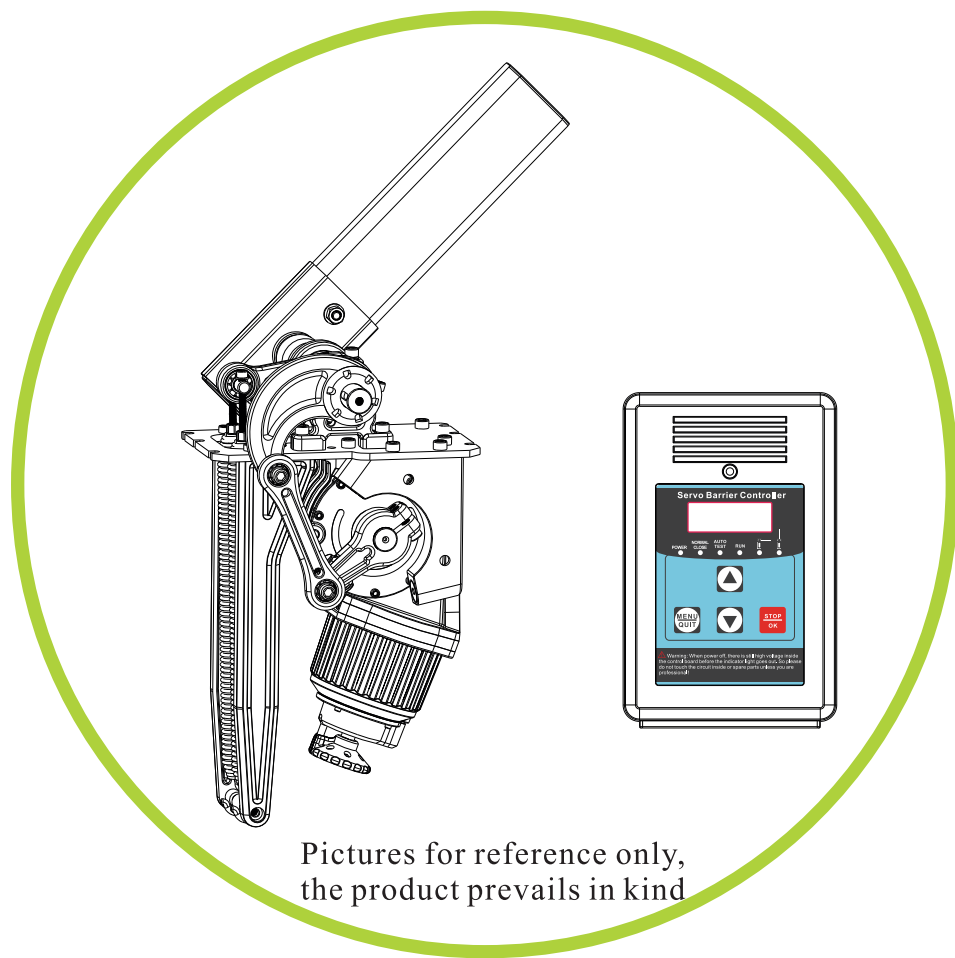

Manual



Servo Barrier Gate



Pictures for reference only,
the product prevails in kind

Contents

1. Brief Introduction.....	1
2. Functions and Features.....	1
3. Technical Data.....	1
4. Mechanism Structure.....	2
5. Installation Direction Definition.....	2
6. Mechanical Part Installation and Adjustment.....	3
6.1. Installation of Cabinet.....	3
6.2. Spring Selection, Installation and Adjustment.....	3
6.3. Mechanism Installation Direction Change	4
6.4. Motor Hand-Wheel Lock Usage.....	5
7. Controller Explanations and Instructions	6
7.1. Controller Interface Explanations.....	7
7.2. Controller Menu Setting Explanations.....	7
7.3. Function Explanations.....	8
7.4. Controller Auto-Detect after Power-On Description.....	9
8. Common Malfunctions and Solutions.....	10
9. Warranty and Service Items.....	10
10. Maintenance.....	10
11. Packing List.....	11
Appendix	
I. Remote Control Coding.....	11
II. Wiring Diagram for R&G Light Interface.....	12
III. Drive Requirement for Main Control Board Wire Control.....	12
IV. Wire Diagram for Two Barrier Gates Work Online.....	13
V. RS485 Communication Protocol.....	14
VI. Digital Tube Display Character Interpretation.....	15

Warning!

For safety, please do follow the instruction strictly to manage this product:

1. It is forbidden to open the barrier cabinet top cover or door when it is working.
2. There must be a grounding connection for the barrier cabinet.
3. Make sure there is no person or any obstruction under the boom when it is falling.
4. Before delivery, the barrier gate spring and the boom length are well-balanced. It is not allowed to change the boom length randomly. If needed, please check with the technician.

1. Brief Introduction

This is our newly-produced DC servo barrier gate, which utilizes the updated electronic control technology and machinery processing technology, no limit switch design, to realize non-adjust of mechanism, adjustable speed, automatic speed reduction, ext. In this way, make the barrier operate more steadily and more reliably. This product is highlighted in frequency applications and longer lifetime.

2. Functions and Features

- 2.1. Innovative motor hand-wheel lock design: lift up the boom by hand when power off, pull the motor hand-wheel lock to lock the barrier; release the motor hand-wheel lock to run when power-on.
- 2.2. No limit switch design: the motor can detect the boom position automatically.
- 2.3. Bi-direction boom holder design: left-installation and right-installation can be exchanged easily and quickly.
- 2.4. Self-detect after power-on, open/close speed is adjustable.
- 2.5. With auto-reversing on obstruction function.
- 2.6. Infrared photocell interface is available. (need to install photocell device).
- 2.7. Loop detector interface is available, to avoid hitting the vehicle, and control the boom falling down automatically after vehicle passing. (need to install loop detector)
- 2.8. Built-in counting function, can store the times of opening signal, deduct the times when vehicle passing the loop, boom falling down after vehicle passing through, well improve the traffic efficiency.
- 2.9. Built-in delay auto-closing function, coordinated with counting function, if the numbers of vehicle passed less than the stored numbers, the boom will fall down automatically by countdown, but will be new countdown if there is up or loop detector signal.
- 2.10. Integrated RS485 communication interface, to realize control of barrier open/close by computer and barrier status query.
- 2.11. RJ45 network module can be added, to realize control of barrier open/close by computer network and barrier status query.
- 2.12. With auto-aging test function.
- 2.13. NO/NC wire control signal input are optional.
- 2.14. 4-digit digital tube display, display more information.

3. Technical Data

- 3.1. Working temperature (motor): $-30^{\circ}\text{C} \sim +85^{\circ}\text{C}$
- 3.2. Working Power: $110\text{V} \pm 10\%$, $110\text{V} \pm 10\%$
- 3.3. Motor Power: 100W MAX
- 3.4. Humidity: $\leq 90\%$ RH
- 3.5. Distance of remote control: $L \geq 30\text{M}$
- 3.6. Insulation Grade: F

4. Mechanism Structure

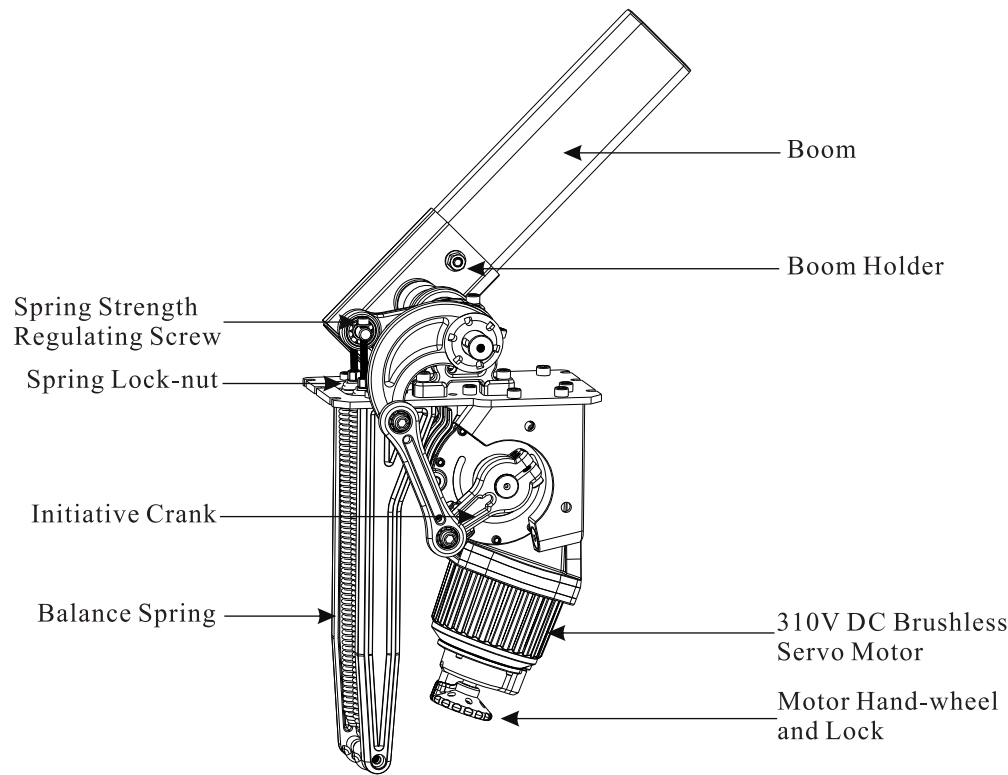

(Figure 1)

5. Installation Direction Definition

When placing the order, please confirm “left-installed” or “right-installed”. Figures as below:

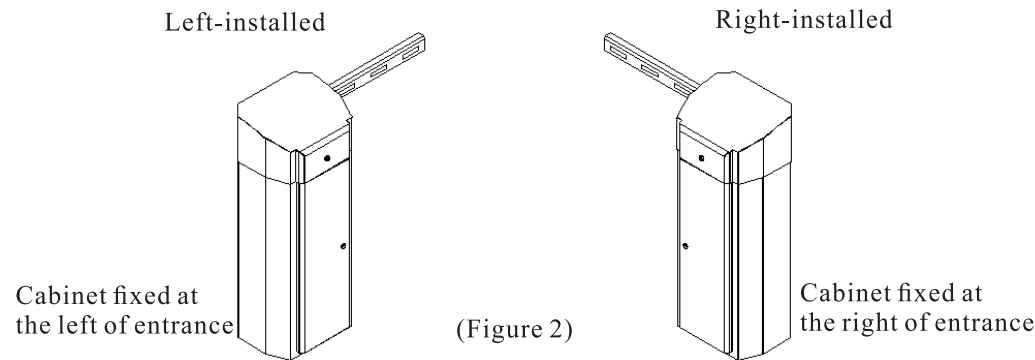

6. Mechanical Part Installation and Adjustment

6.1. Installation of cabinet

Please select the correct type of barrier gate according to the specifications of the place, and then fix the barrier cabinet with expansion bolts. (refer to Figure 3)

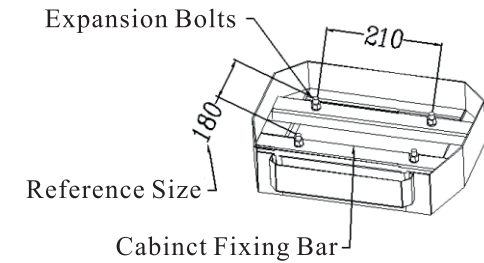

(Figure 3)

(According to the supplementary size)

6.2. Spring selection, installation and adjustment

The barrier gate is well-adjusted before delivery. If need cut off the boom, please reset the menu “ Boom Length Selection” in the control unit to ensure the smooth operation of the barrier.

6.2.1. Spring selection

The length of spring prevails in kind, designing change without notice. The spring selection please refer to the spring table which stick on the door of the barrier cabinet.

6.2.2. Spring installation, disassembly and replacement

Dismantlement steps: Keep the boom at vertical position, see figure 1, loosen the spring fastening nuts, unscrew the M8*140 spring adjusting screws by a hexagonal spanner, then take off the spring.

The steps for installation and disassembly the spring are the opposite.

6.2.3. Spring force adjustment

When power off, hand up the boom at 45 degrees, if the boom can keep balance means the spring force is at best status, no need to adjust; if the boom falling down means the spring force is too weak, need to tight the spring. If the boom lifting up means the spring force is too strong, need to loosen the spring.

6.3. Mechanism installation direction change

This barrier mechanism can be both left-installed and right-installed. The users can change the installation direction according to the actual situation. We will take the left-installed barrier mechanism as an example. The below description is telling you how to change from left-installed to right-installed:

6.3.1. Disassemble boom holder: take out the 10MM screw by turning 8MM Allen wrench counterclockwise; And then push out the boom holder by turning wrench clockwise with a 14MM* 150 screw.

6.3.2. Change the mechanism installation direction: disassemble 6 sets 8MM screws for fixing the mechanism panel, turn the mechanism 180 degrees vertically and put back into the cabinet. And then fix it with the 6 sets screws.

6.3.3. Assemble boom holder: assemble the boom holder back, and fix the 10MM screw by turning 8MM Allen wrench clockwise. And then the mechanism installation direction change is finished.

Take out the 10MM screw by turning 8MM Allen wrench counterclockwise

Push out the boom holder by turning wrench clockwise with a 14MM* 150 screw

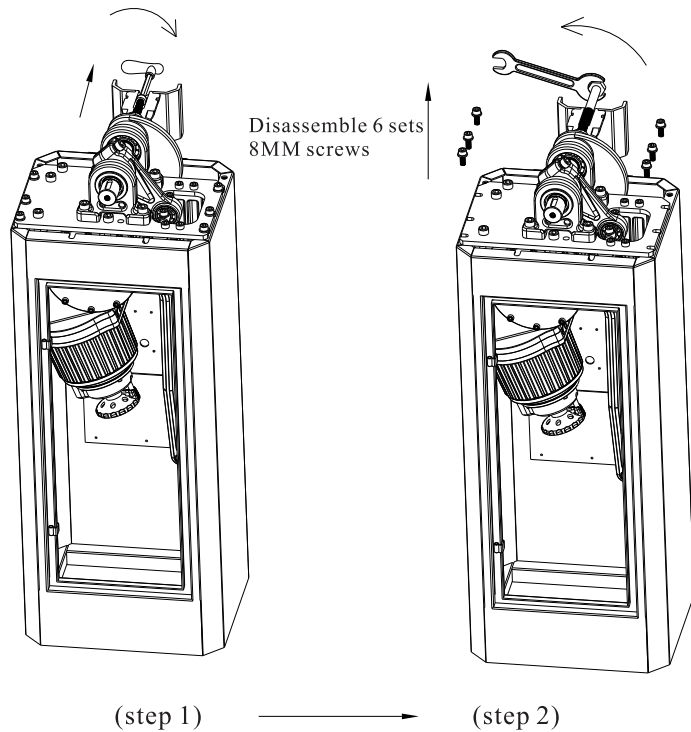

Turn the mechanism 180 degrees vertically

Put the mechanism into the cabinet

Assemble the boom holder back, and fix the 10MM screw by turning 8MM Allen wrench clockwise

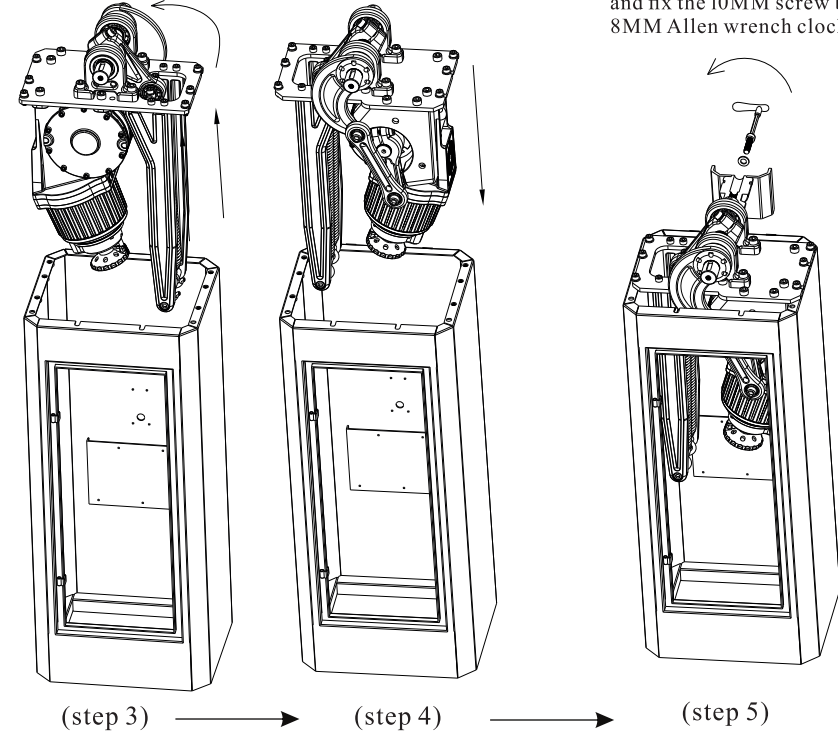

6.4. Motor hand-wheel lock usage

During power off, can use motor hand-wheel lock to lock. See the photo as following, pull the handle into the fixed slot to lock. When power on, pull out the handle to unlock, or the controller will display Er.6. (If displaying Er.6, need to unlock and then power on again).

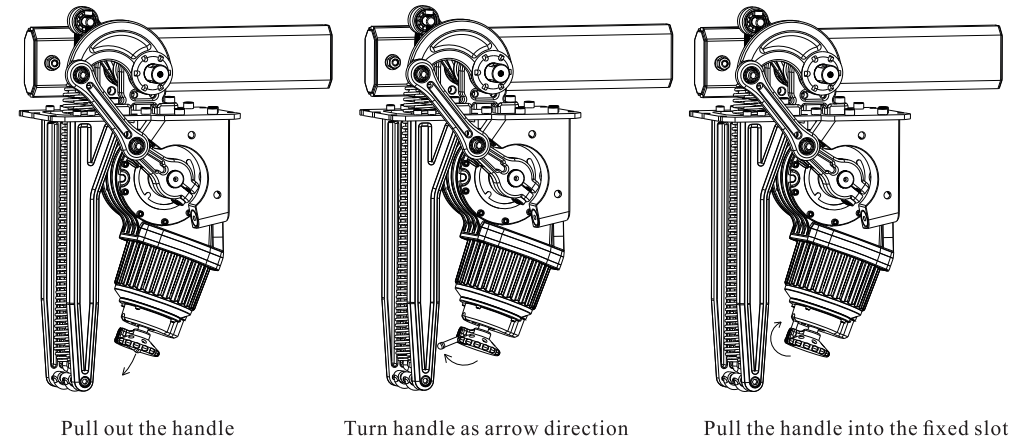

7. Controller Explanations and Instructions

Controller Description

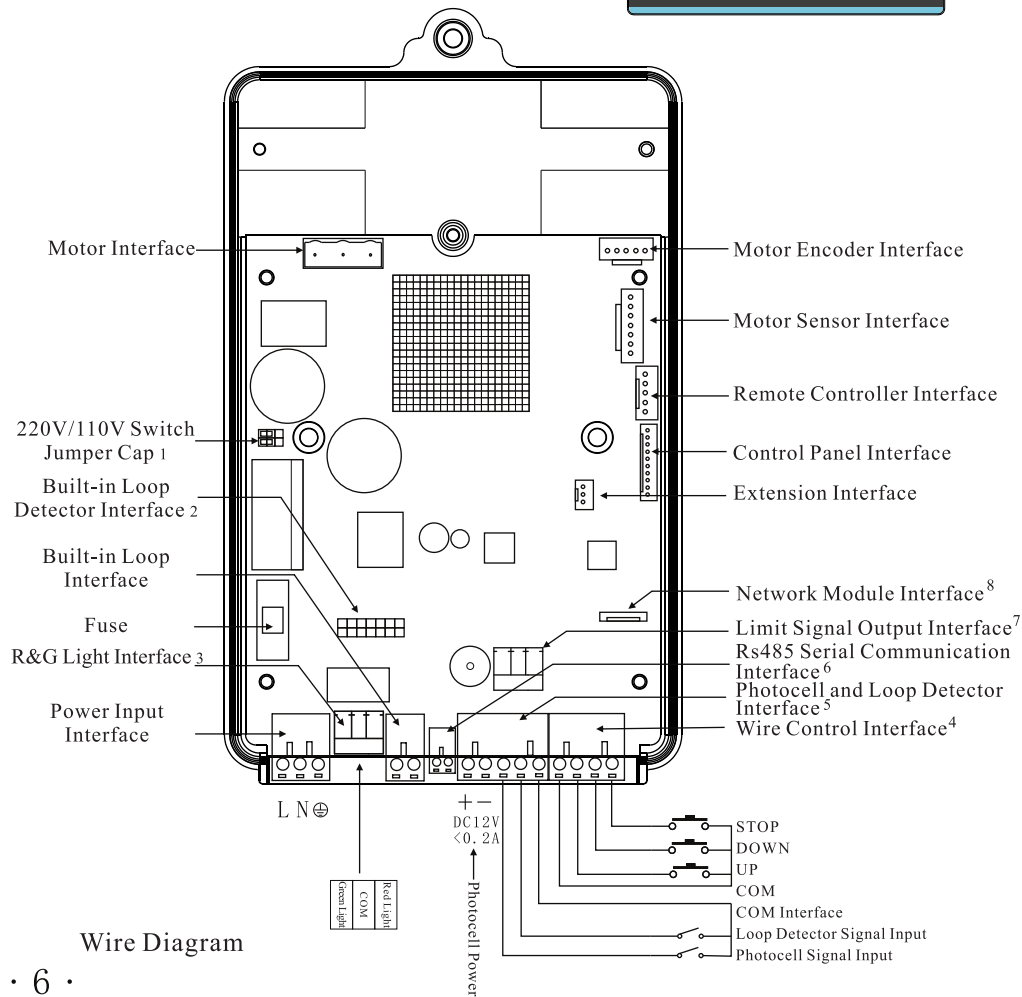
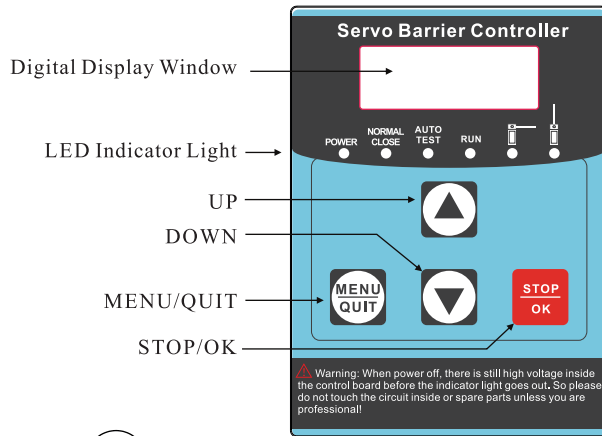

Wire Diagram

7.1. Controller interface explanations

All the electrical connections are done before delivery. The necessity is to connect the power and grounding connection. Explanations and instructions for the main function interfaces and indicator light is as following:

7.1.1. 220V/110V switch jumper cap:

This barrier motor and controller support AC220V/110V power input, the jumper cap is plugged in before delivery, if need to change the input voltage, please plug the jumper cap into correct position before power on (plug on the left is 220V, plug on the right is 110V).

7.1.2. Built-in loop detector interface:

This interface supports the company's supporting coil type car detector (loop detector) module or radar inspection module; If using loop detector, the loop needs to connect to "Built-in Loop Interface".

7.1.3. R&G light interface:

This function is no power, same as switch, "COM" need to connect with corresponding power of the R&G light. When boom falling down to horizontal position, red light will keep lighting; when boom lifting up to vertical position, green light will keep lighting. During the boom falling down or lifting up, the red light will keep lighting. (Please refer to Appendix II for wire diagram)

7.1.4. Wire control signal input interface:

This interface is dry contact input signal, UP▲/DOWN▼/STOP■ connect with "COM", the control board will respond accordingly. User can use this interface to connect with parking system, and it can also connect button switch to control the barrier. (Please refer to Appendix III for drive requirement for main control board wire control)

7.1.5. Photocell and loop detector interface:

This interface is dry contact input signal, only for responding opening when shorts circuit "Photocell" and "COM" during closing, responding closing when shorts circuit "Loop" and "COM" if opening to up limit position, responding opening when shorts circuit "Loop" and "COM" during closing, and after opening to up limit position, "Loop" and "COM" disconnected, then close automatically.

7.1.6. RS485 serial communication interface:

This interface is for connecting the computer serial port via UTP-unshielded twisted pair and RS485-RS232 convertor, or connecting the computer USD interface by USD-RS485 convertor. Realize computer control the barrier and inquire the status of barrier by communication protocol. Address is set by setting menu. Please refer to Appendix V for the communication protocol. Also can use for two barrier gates work online (Please refer to Appendix IV).

7.1.7. Limit signal output interface:

This interface is DC12V active signal output (series 100ohm resistor) for opening to up limit 0.END/closing to down limit C.END, system can get the signal of boom position from this interface.

7.1.8. Network module interface:

This interface supports the company's supporting network module, to realize control of barrier open/close by computer through local area network and barrier status query.

7.2. Controller menu settings explanations

7.2.1. Setting method:

In up or down limit position, long press  for X seconds entering to menu setting. Press  or  to choose function. Then press  to finish selection. Press  to exit setup section.

Long pressing time: $0.5 < X < 3s$, setting contents are regular menu items (P1~P9).

Long pressing time: $3s < X$, setting contents are advanced menu items (PA, Pb, and Pc).

7.2.2. Regular menu—Content

P1.X Auto-reversing on obstruction function: 0: Stop on obstruction

1: Lighter intensity

2: Light intensity (default)

3: Middle intensity

P2. X Counting function: 1: Open; 2: Close

P3. XX Delay auto-closing function: 0: Close; 3~60: the time of delay auto-closing.
(unit: seconds)

P4. XX R485 address: 0: Online; 01~99: address code

P5. XX Boom up angel: The number means boom up angel; default is 90 degree

P6. XX Boom horizontal adjustment: 00 to 40 gears

P7. XX Boom vertical adjustment: 00 to 25 gears

P8. X. X Boom up speed:  CB01SV-H: 1.2 / 1.5 / 2.0 (Boom length $\leq 4.5M$)

P9. X. X Boom down speed: CB01SV-I: 3.0 / 4.0 / 5.0 (Boom length $\leq 6M$)

Note: The number is passing speed, unit is seconds.

7.2.3. Advanced menu-Content

PA. X Auto-aging test: 0:Close (default), 1: Open

Pb. X Signal type: 0: Normal close; 1: Normal open (default)

Pc. X Learning mode after power-on: 0: Boom up and down (default); 1: Boom up only

Pd. X Motor hand-wheel lock monitoring: 0: not monitoring; 1: monitoring (default)

7.3. Function explanations

7.3.1. Auto-reversing on obstruction function:

When the boom meets obstruction during falling down, it will auto-reverse (lift up) or stop.

7.3.2. Counting function:

Record the number of times (N) for boom up by wire control. When the number (N) of vehicle passing through the loop, the boom will fall down automatically.

7.3.3. Delay auto-closing function:

When the boom opens to the up limit position, if there is no vehicle passing through the loop during the setting time, the boom will fall down automatically; if there is open signal, it will be countdown again. If there is stop signal, the boom will fall down at once.

7.3.4. RS485 communication function:

When the two barrier gates work together, the host can be set to 0: "Online mode" (see Appendix V for details). When using upper system (such as computer) to control, can choose address code from 01 to 99.

7.3.5. Up limit angle:

The angle is that the boom opens to up limit position; the angle can be set if there is obstacle in the vertical position. (Note: If the setting is not 90 degrees, the learning mode cannot be set to "Boom open only")

7.3.6. Boom horizontal adjustment:

Fine adjust the boom in horizontal position. The boom will go upward when the value is small; it will go downward when the value is big.

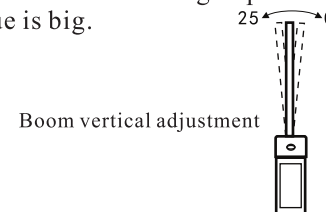
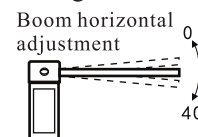

7.3.7. Boom vertical adjustment:

Fine adjust the boom in vertical position. The boom will go forward when the value is small; it will go backward when the value is big.

7.3.8. Boom up speed:

Setting the speed of boom up.

7.3.9. Boom down speed:

Setting the speed of boom down.

PA. Auto-aging test:

Open this function to realize the barrier gate open, close and open during closing process for aging test. After power-off and restart, the operation will continue. This function can be cancelled by pressing stop button.

Pb. Signal Type:

It means the input type of "stop", "loop detector" and "photocell" of wire control signal. "Normally Open" means the response action when the signal and common interface are short-circuited; "Normally Close" means the response action when the signal and common interface are disconnected; the signal of this controller is "Normally Open" by default.

Pc. Learning mode after power-on:

When power-on, the barrier gate will slowly opens and closes one time by default. If working with a long fence boom, the barrier may not be able to close due to the deformation of the boom. At this time, you can set the learning mode to 1: "Boom up only".

Pd. Motor hand-wheel lock monitoring:

Controller will monitor the status of motor hand-wheel lock, if the monitoring sensor failure, and the status of motor hand-wheel lock still prompt error message (Er. 6), can set Pd. to be 0 (close motor hand-wheel lock monitoring function), let the barrier gate work temporarily.

7.4. Controller auto-detect after power-on description.

The controller should be learning the position of boom after power-on: The barrier gate will slowly open and then close one time by default. During learning process, it detects all open and anti-bumping signal interface, and it will stop learning if there is signal. Meanwhile, the digital tube displays the related signal information (refer to Appendix VI), and relearning after the signal disappears. After finish leaning, the boom stays at the down limit position.

The digital tube will display "Er. 5", if the barrier installed spring but no boom, or there is obstruction on the boom during up or down process, or the spring and boom in serious imbalance, need to remove the obstruction or adjust the spring, then power-on again.

If learning mode is "Boom up only", the barrier gate will open to up limit position, and not close; during learning process of opening, if the barrier can't open to up limit position due to obstruction, although prompted finish learning, but can't close normally.

8. Common Malfunctions and Solutions

8.1. When power-on, press “UP” or “DOWN” button, there is no reaction on the boom.

- 8.1.1. Check up the power supply and the fuse.
- 8.1.2. Check if the remote controller matches the radio receiver; or check up the battery inside and then change it if it is lack of power.
- 8.1.3. Check whether there is co-channel interference, and press the buttons on the control board to check if can work.
- 8.1.4. Check up if the external protection circuit is failure or in protection status. Check up the condition of photocell and loop detector are lighting.

8.2. The barrier gate closes half, and then stop learning, during controller self-test after power-on.

- 8.2.1. Check up if the boom is installed, the barrier gate need to work with boom if springs installed.

8.3. Fence boom or 6m boom lifts up automatically when closing.

- 8.4.1. Check up “Auto-reversing” and set it to be “3”.

9. Warranty and Service Items

- 9.1. Free service is offered for component parts in one year warranty time. (not includes the barrier boom or remote)
- 9.2. Lifetime service with charge accordingly.
- 9.3. Technical questions are supported.
- 9.4. The below items and situations are not included in the range of free service:
 - 9.4.1. The user does not follow the instruction and cause any damage of the product.
 - 9.4.2. The power supply is not stable, over the range of permitted voltage or not accordant to safety electric using standard.
 - 9.4.3. The user installs or uses the product in wrong methods, cause damage to the appearance of product.
 - 9.4.4. Natural disaster causes damage to the product.
 - 9.4.5. Warranty time is over.
 - 9.4.6. Service items are out of our promises.

10. Maintenance

- 10.1. Keep the barrier gate clean.
- 10.2. Check the joints ever month in case of any loose parts.
- 10.3. Check the balance status of spring after the barrier gate running 1 million times; change new springs after running 3 million times, to avoid spring breaking due to excessive fatigue.
- 10.4. Check the easily worn-out parts every half year and renew it.
- 10.5. Remote control distance will be shortened or not work in cases like big object screening, battery exhausting, extreme weathers.

11. Packing List

Name	Specification	Quantity	Unit	Application
Screws, Nuts, Flat Pad	M12*70	2	sets	Fixing the boom
Boom Fixing Bar		1	pcs	Fixing the boom
Boom Holder Plastic Cover		1	sets	Optional
Cabinet Fixing Bar		2	pcs	Fixing the cabinet
Expansion Screws	M16*150	4	sets	Fixing the cabinet
Support Post		1	pc	Optional
Radio Emitter		1	pcs	Optional
Keys		2	pcs	For cabinet door
Remote Controller		2	pcs	
Manual		1	pcs	

Appendix I: Remote Control Coding

Two types of remote control, multi frequencies for choice. If need to add or change remote control, methods as following:

1. Learning type

Learning method 1: Before connect power to the barrier gate, keep pressing button “STOP”, then connect to power, after about 6 seconds, indicator of the receiver from lighting to flashing 4 times then off. That means learning well. (Note: during learning, please don't loose the button, or you need to relearn).

Learning method 2: Press button “UP” and “STOP” of the well learning remote controller at the same time for 4 seconds, indicator of the receiver keep lighting means entering to learning status; during 3 seconds, press button “STOP” of the not learning remote controller for 2 seconds (or press 2 times continuously), indicator of receiver flashes 4 times. That means learning well. If the remote controller doesn't receive any effective signal, it will quit learning status.

Clear the code of remote controller: take out the cover of the radio receiver, and power on, then make short circuit of the left 2 dial plate on the receiver mould, until the indicator goes out. Then the code of remote controller is cleared.

2. Fixing type:

The code of remote controller and receiver should be the same.

Coding method: open the remote controller, take out the battery, there is dial plate, the direction is from right to left. The solder between middle port and top port is state “1”. The solder between middle port and bottom port is state “0”. Empty is state “X”. The code as below is 10XX0X1X (Warning: please take out the battery before coding!).

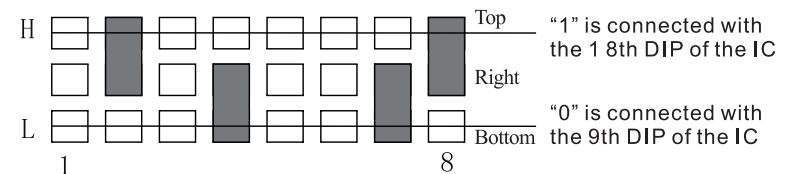

Appendix II: Wiring Diagram for R&G Light Interface

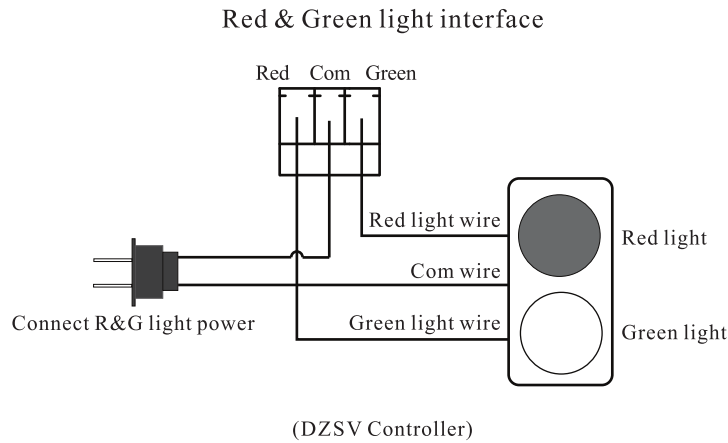

Appendix III. Drive Requirement for Main Control Board Wire Control

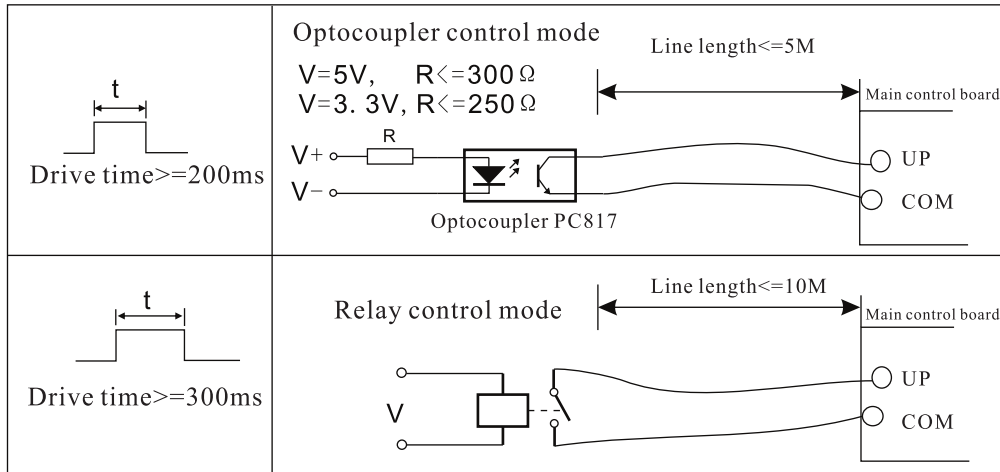

Appendix IV. Wire Diagram for Two Barrier Gates Work Online

If two barrier gates work online, controller supports two mode: RS485 online and wire control online.

①RS485 online mode: The controller which connects with open signal and loop detector signal, defined as host controller, entering regular menu setting, sets P4. XX to be P4.; Another controller defined as slave controller, which RS485 address, sets to default P4.1. Connect D+ and D- one-to-one correspondence of RS485 interface on the host controller and slave controller by wire (recommended twisted pair). This online model just need two wires.

②Wire control online mode: Connect “COM, Open signal, Close signal, Loop signal, Stop signal” of wire control interface on two controllers by wires, need 4pcs wires at least (if the quantity of pre-buried wires is not enough, the seldom used “stop signal” can be ignored).

Note: In higher requirements, the above two modes can be used at the same time. Besides, the code of the radio receivers of two barrier gates can be set same, to improve synchronization consistency of the remote.

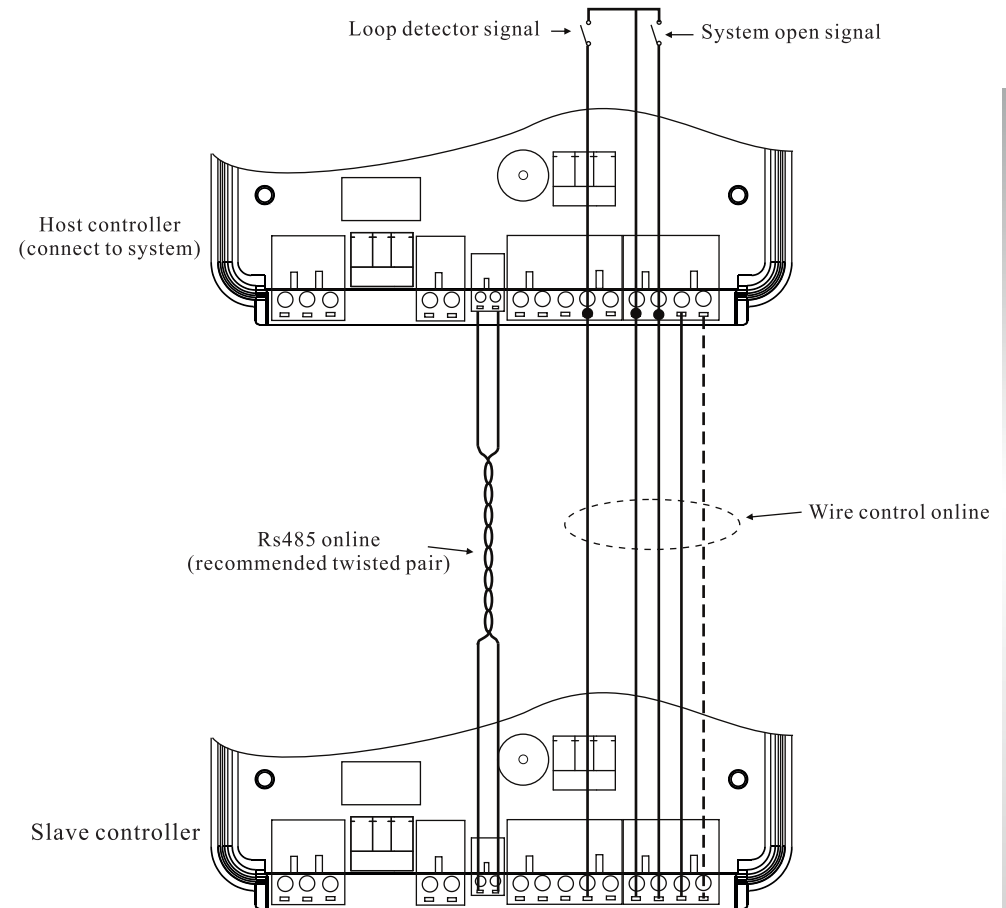

Appendix V. RS485 Communication Protocol

Communication format: 16 hexadecimal, Baud rate: 19200.

Date format sent by upper system: Data header (fd xx) + Address + Command + (data) + End code(fd fa).

However, XX cannot be fd or fa (address in following example is 00).

Data format returned by controller: Data header (fd 00) + Address + Command + (data) + End code (fd fa).

Some commonly used command tables (address in following example is 01), for more command, please ask our customer service for electronic files).

-
1. Upper system sends search command: 00 send stream code is: fd 00 01 00 fd fa
Barrier controller returns: 00 intermediate state/09 up to limit position/0c down to limit position
If the barrier in the up limit position, the return stream code: fd 00 01 09 fd fa
-
2. Upper system sends open command: 03 send stream code: fd 00 01 03 fd fa
Barrier controller return 03 return stream code: fd 00 01 03 fd fa
-
3. Upper system sends close command: 05 send stream code: fd 00 01 05 fd fa
Barrier controller return 05 return stream code: fd 00 01 05 fd fa
-
4. Upper system sends lock command: 07 send stream code: fd 00 01 07 fd fa
Barrier controller return 07 return stream code: fd 00 01 07 fd fa
-
5. Upper system sends uplock command: 08 send stream code: fd 00 01 08 fd fa
Barrier controller return 08 return stream code: fd 00 01 08 fd fa

(Note: After the lock command takes effect, the barrier controller no longer responds to any action, only accepts the unlock command or restart)

Appendix VI. Digital Tube Display Character Interpretation

Malfunction information description and solution

Er. 1 Memory failure

Solution: Change a new control, or setting the menu well when power-on to make the barrier gate as a temporary emergency use.

Er. 2 Current detection circuit failure

Solution: Change a new controller

Er. 3 Motor can't be detected, or motor circuit is abnormal

Solution: Check if all motor-related wires are in good contact.

Er. 4 Encoder data out of range

Solution: Check if the controller matches the barrier mechanism.

Er. 5 Position learning failed

Solution: Check if the spring is seriously out of balance.

Er. 6 Motor hand-wheel lock is not unlocked

Solution: Check if motor hand-wheel lock is unlocked.

Input signal after power-on prompt information description

Er. L0 There is STOP signal input from wire control

Er. L1 There is CLOSE signal input from wire control

Er. L2 There is OPEN signal input from wire control

Er. L3 There is signal from loop detector

Er. L4 There is signal from photocell

Er. L5 There is STOP signal from remote control

Er. L6 There is CLOSE signal from remote control

Er. L7 There is OPEN signal from remote control

Limit status display description

Luxx Up limit angel, xx means the angel

Ldxx Down limit and closing speed, xx means closing speed

xxx c Motor temperature display, xxx means temperature value

dExx Delay auto-closing, xx means countdown time

uPxx Times of open memories when open the counting function, xx means times

Opening/closing process display description

--xx --scroll up means opening, xx means opening speed

-- --scroll down means opening, xx means opening speed

---- means stop

Auto-reversing on obstruction prompt

Er. ob