



# Integrated Fixed Reader User Manual (V1.0.2)

Línea 72



# CONTENTS

1	Technical specifications .....	5
1.1	Product features .....	5
1.2	Main functions & technical specifications .....	5
1.2.1	The main function .....	5
1.2.2	Performance Parameters .....	5
1.2.3	Work Environment .....	6
2	Physical structure .....	7
2.1	Physical structure .....	7
2.2	Weight .....	8
2.3	Interface definition .....	8
3	Installation description .....	10
3.1	Precautions .....	10
3.2	Installation conditions .....	10
3.3	Device connection .....	10
3.3.1	Connect the power adapter .....	10
3.3.2	Connecting a PC .....	10
3.4	Installation .....	11
3.5	Installation steps .....	11
3.5.1	Horizontal pole installation .....	11
3.5.2	Vertical pole installation .....	12
3.6	Acceptance .....	13
3.6.1	checking physical installation .....	13
3.6.2	checking reader performance .....	13
4	Common failure phenomenon .....	14

4.1 Daily maintenance .....	14
4.2 Common failure analysis & resolutions .....	14
5, Packaging, accessories, transportation & storage. ....	<b>15</b>
5.1 Packaging: .....	15
5.2 Accessories .....	!
5.3 Storage requirements .....	16
6. After-sale service .....	<b>17</b>

# 1 Technical specifications

## 1.1 Product features

2E-7206 is a high performance UHF RFID device in integrated 9dBi circular antenna and reader all in one. Supports ISO18000 -6C/6B protocols. The work frequency includes China standard dual frequency 920MHz ~ 925MHz and 840MHz ~ 845MHz, FCC 902MHz ~ 928MHz and ETSI 865MHz ~ 868MHz.

Output power from 18 ~ 25 dBm optional, with long identification distance, strong anti-interference ability, good protection performance and easy installation

## 1.2 Main functions & technical specifications

### 1.2.1 The main function

Air interface protocol: supports all mandatory commands ISO18000 -6C

Rich communication interfaces (serial, RS485)

Support tag data filtering

RF output power adjustable

Operating modes: fixed frequency / hopping optional

Support on line upgrade

I/O interface: 1 optocoupler input, 1 pair 5V relay output or wiegand output (wiegand output is shared with 5V relay output)

### 1.2.2 Performance Parameters

Working frequency: GB 920MHz ~ 925MHz, GB 840MHz ~ 845MHz,

FCC 902MHz ~ 928MHz, ETSI 865MHz ~ 868MHz

RF output power (Port): 25 dBm ± 1dB (MAX)

Output power adjustment: 1 dB step-by-step

Read the label from the 0 to 6 m (and tag antenna and the use of environment - related)

Channel bandwidth: <200KHz

Built circularly polarized antenna VSWR: ≤1.2: 1

Built-in circularly polarized antenna gain: ≥8dBi

RS232 serial communication rate: 115200bps (default), 19200 bps, 9600bps

RS485 interface communication rate: 115200bps (default), 19200 bps, 9600bps

Support: Wiegand 26, 34, 66 interfaces

Power (power adapter): AC input 100V ~ 240V, 50Hz ~ 60Hz

DC output 24V  $\pm$  1.5V/2.5A

High degree of protection: IP65

### 1.2.3 Work Environment

Operating temperature range: -20 ~ +70

Relative humidity: 5% RH ~ 90% RH (+25 )

## 2 Physical structure

### 2.1 Physical structure

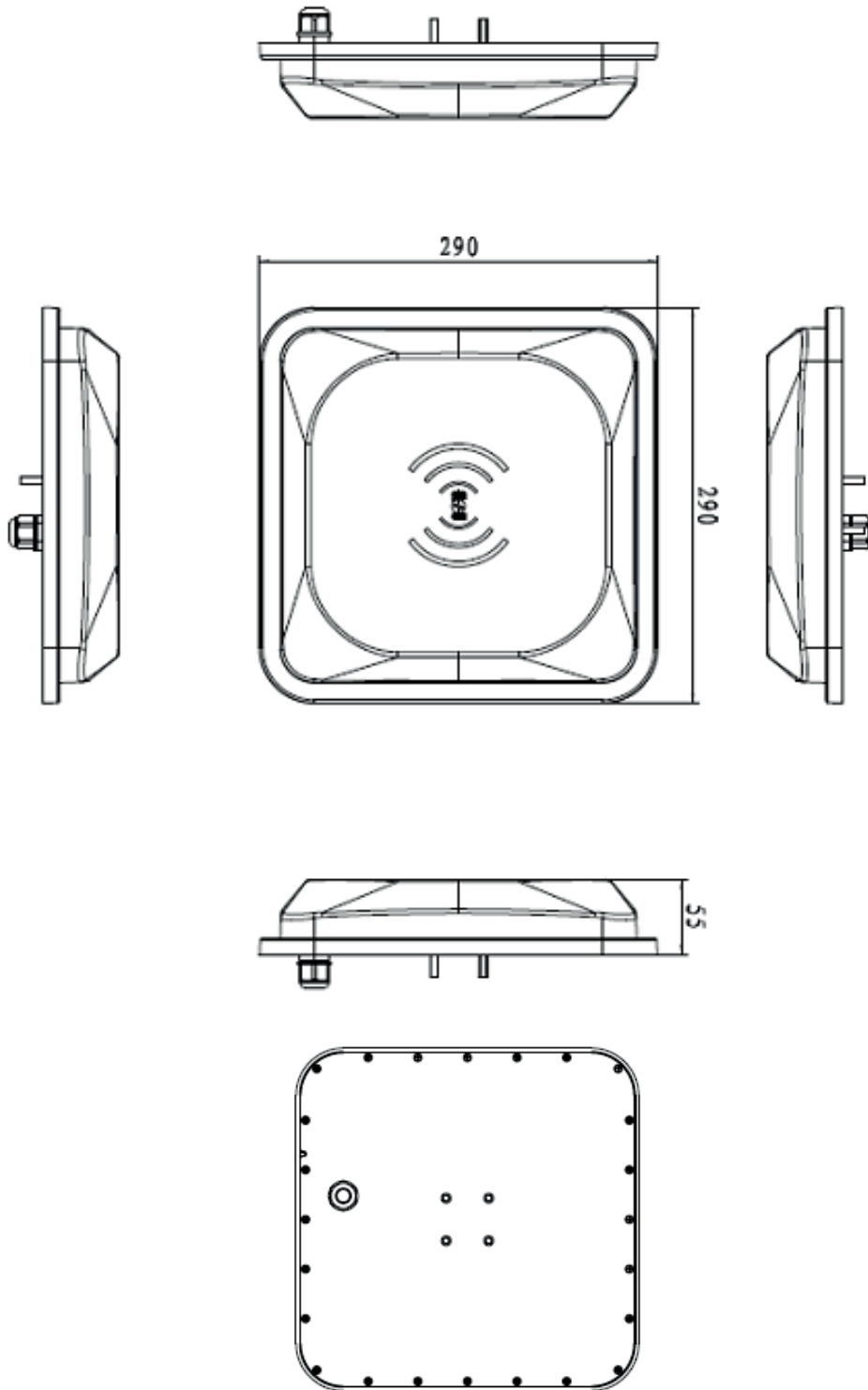

Pic 2 - 1 2E-7206 physical structure

2E-7206 reader size

290mm × 290mm × 55mm (accessories not included)

## 2.2 Weight

1.6kg (accessories not included )

## 2.3 Interface definition

This reader use 14 cores cable for power support and data communication. Detailed definitions as in following table:

No.	Color	Definition
1	Black	GND
2	Brown	GND
3	Red	24V
4	Orange	GPO2/wiegand 1
5	Yellow	GPO1/ wiegand 0
6	Green	GPI
7	Blue	N/A
8	Purple	N/A
9	Grey	N/A
10	White	N/A
11	Light blue	RS485 -
12	Light green	RS485 +
13	Brown white	Serial port receive (RXD)
14	Black white	Serial port transmit (TXD)

For reader RS232 wire connection, please refer to below information:

Below is the pin-out of a typical standard male 9-pin RS232 connector, this connector type is also referred to as a DB9 connector.

A computer's serial COM port (DTE) is usually a male port as shown below, and any peripheral devices you connect to this port usually has a female connector (DCE).

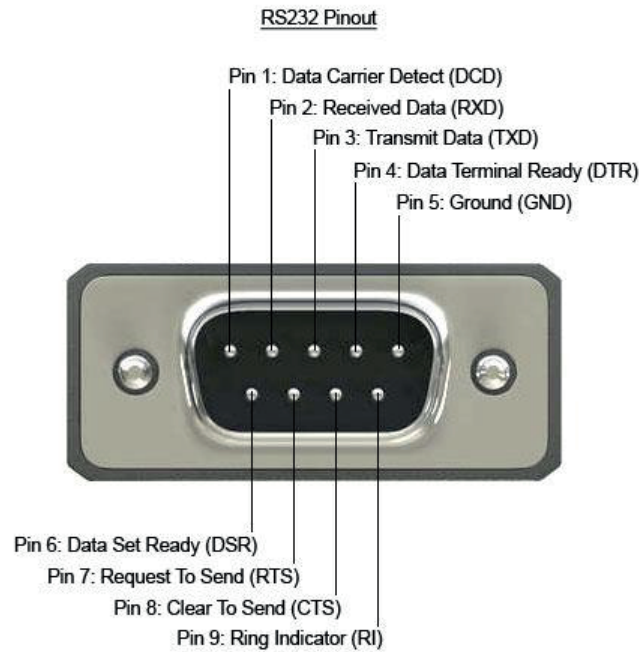

Pin	Signal Name	Dir	Description	Connect to reader
1	DCD	In	Data Carrier Detect	
2	RXD	In	Receive Data	14 - Black/white
3	TXD	Out	Transmit Data	13 - Brown/white
4	DTR	Out	Data Terminal Ready	
5	0V/COM	—	0V or System Ground	1 - Black
6	DSR	In	Data Set Ready	
7	RTS	Out	Request to Send	
8	CTS	In	Clear to Send	
9	RI	In	Ring Indicator	



## 3 Installation description

### 3.1 Precautions

In order to ensure normal and stable operation of the equipment and your personal and property safety, please carefully read the following notes before installing 2E-7206 reader device :

1. First check whether the outlet is connected to the ground, and check if the local power supply voltage meet reader voltage requirements;
2. Check if the device is connected tightly;
3. Pay attention to the serial cable type selection and length restrictions;  
  
Serial port cable length 5m maximum.  
  
RS485 length 80m maximum.
4. When installing multiple readers, the antenna position and the antenna spacing should be appropriate to avoid interference with each other.
5. Please test & ensure the reader can work normally before using it.

### 3.2 Installation conditions

Before installing the reader, please carefully check and confirm the product is intact, the accessories are complete, if there are any damages or shortage, please contact your supplier.

### 3.3 Device connection

#### 3.3.1 Connect the power adapter

Connect power adapter to AC power socket, and tighten the other end to reader's power port.

After the circuit is connected, wait for about 12 seconds, reader makes launching sound and enter into initialization state, after initialization is finished, reader enter into standby mode.

#### 3.3.2 Connecting a PC

Reader cable interface includes all signal cords in the interface definition table.

RS-232 interface is used for short-range communication (less than 5m), can be connected to a PC via DB9 connector for communication.

RS-485 port is used for longer range serial port communications (less than 80m) ;

### 3.4 Installation

The reading and writing range of the reader depends on the on-site application, the tilt angle of the antenna is adjusted to achieve the best reading and writing performance.

### 3.5 Installation steps

#### 3.5.1 Horizontal pole installation

(1) Align the L-shaped mounting bracket against the screw poles on bottom of reader housing, then install the rubber and screw the M6 nuts, refer to pic 3-1:

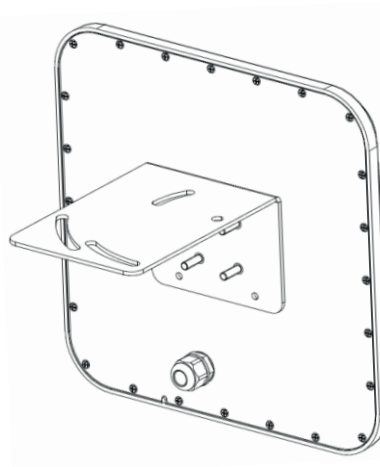

Pic 3-1 L-shaped mounting bracket installation

(2) Using two U-bolts and two toothed installation bracket to fix the reader on vertical rod through the L-bracket. As per illustrated in picture 3-2.

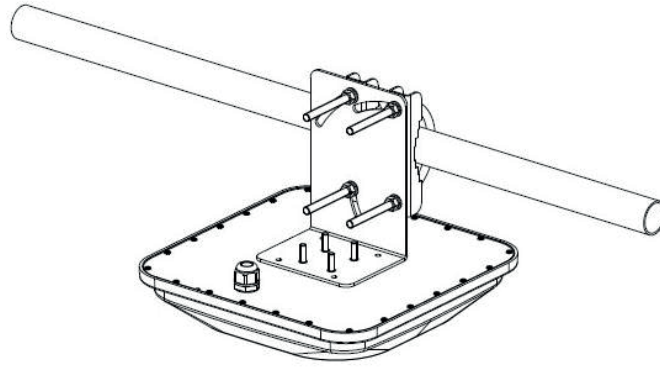

Pic 3 -2 Horizontal pole installation

### 3.5.2 Vertical pole installation

(1) Align the L-shaped mounting bracket against the screw poles on bottom of reader housing, then install the rubber and screw the M6 nuts, refer to pic 3 --3:

(2) Using two U-bolts and two toothed installation bracket to fix the reader on vertical rod through the L-bracket, refer to pic 3 --4.

Note: This installation method is suitable for 50mm ~ 100mm diameter horizontal pole.

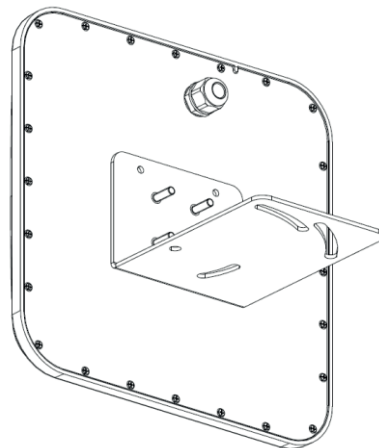

Pic 3 -3 L-shaped mounting bracket installation

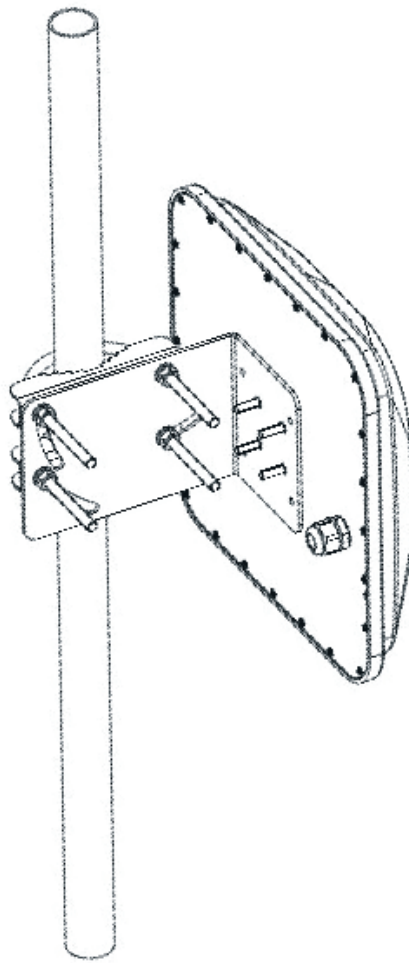

Pic 3-4 Vertical pole installation

### 3.6 Acceptance

#### 3.6.1 Checking physical installation

Check & ensure the reader is fixed safely;

Check & ensure cables are connected securely.

Check & ensure screws are screwed firmly.

#### 3.6.2 Checking reader performance

check & confirm the reader is working normally ;

check & confirm the reading range is set properly.

## 4 Common failure phenomenon

### 4.1 Daily maintenance

Check & ensure if the RF connector is fixed firmly

Check & ensure the screw that fixes reader & antenna is not loose.

Check & ensure the RF cable connection point skin is not peeling off.

Check & ensure if the power supply cable is connected well.

### 4.2 Common failure analysis & resolutions

Power supply abnormal

Check if the power supply is in normal status, if the AC power voltage is 100V~240V.

Serial port failed connection

Check if the serial port cable is connected stable or not .

Check if the serial port connection baud rate is correct.

Check if the serial port number is correct.

#### **Reader can not read tag.**

Check if antenna number is set correctly. If antenna is connected with 1# RF port, then

Please ensure to select 1# antenna in software interface.

Check if tag is damaged. If cannot get ID number, you can use another reader to read this tag to judge if this tag is damaged.

Check if tag is placed in effective reading range.

Check if the electromagnetic interference between the reader and the other device.

For the problems which cannot be solved locally, please contact Hopeland after-sales for repairing.

## 5, Packaging, accessories, transportation & storage.

### 5.1 Packagin g:



Pic 6 - 1 carton box size

Packaging carton box size: 350 mm×350 mm× 190mm

### 5.2 Accessories

Pic 6 - 2 accessories list

No.	Name	Material code	Unit	Qty	Remarks
1	2E-7206 reader	2605283500000 2	1	pcs	Included
2	Power adapter 2 4V/2.5A	20109000000324	1	pcs	Included
3	AC power cable	20350000000195	1	pcs	Included
4	Installation bracket	20412000002647	1	pcs	Included
5	Warranty card	20420000001651	1	pcs	Included
6	Certificate of approval	20420000001650	1	pcs	Included

### 5.3 Storage requirements

Long time storage should be made in following conditions:

Environment temperature : -40 ~ +85

Relative humidity : 5% RH ~ 95%RH